

# TRI-STATE RODEO ASSOCIATION, INC., RULE BOOK

## TABLE OF CONTENTS

I.	General Rules	2
II.	Halter Classes	8
III.	Judged Performance Classes	9
IV.	Timed Speed Events	13
V.	Youth Events	16
VI.	Pee Wee Horsemanship	18
VII.	Adult Classes	18
VIII.	Queen/King Pageant	18
IX.	Constitution	20
X.	By-Laws	23

## 1. GENERAL RULES

1. Any participating show must be put on or sponsored by an organization which is a member in good standing with the Tri-State Rodeo Association, Inc., and approved by the association.
2. Any club or organization holding a Tri-State Rodeo Association, Inc., approved show must have approved contesting and performance classes per each show date.
3. Any club or organization wishing to have a Tri-State Rodeo Association, Inc., approved show must have date of the show approved by the Association at least sixty (60) days prior to the show. No show will be approved less than sixty (60) days before the show date.
4. Member clubs may have one or more Tri-State Rodeo Association, Inc., approved shows per show season. (Refer to By-Laws, Article VII, Rule 10). All show dates will be picked by seniority of member clubs. One (1) show date will be picked per go-around. Any club wishing to retain a prior show date may do so on the first go around. A show date is defined as including both contesting and performance classes.
5. An annual club Membership is ten dollars (\$10.00). Each member club will be required to deposit fifty dollars (\$50.00) for each show date at the time the show date is chosen. Twenty-five (\$25.00) of the fifty dollars (\$50.00) will be held in escrow and may or may not be returned at the end of the show season upon request of the club, provided upon any serious violation of Association rules as determined by the Association's Board of Trustees.
6. Four (4) Tri-State Rodeo Association, Inc., show bills must be sent to the appointed show bill secretary sixty (60) days prior to the show date for approval. The Judge's name must appear on the performance show bill. Upon arrival, the show bill secretary will return one (1) copy with the Tri-State seal for printing. Three (3) copies will be retained for the secretary's files. Show bills can not be altered after approval. Printer's error will not disqualify a class. The approved events must be put out to the public at least thirty (30) days prior to the date of the show.
7. Each club must designate on its show bill the Tri-State Rodeo Association, Inc. approved classes. An asterisk or similar symbol is acceptable.
8. The official rule book of the Tri-State Rodeo Association, Inc. must be posted at the entry booth at all approved shows. All classes on the approved show bill must be offered and follow the rule book.
9. Anyone that violates the Tri-State Rodeo Association, Inc. rules will be subjected to a hearing by the board of Tri-State Rodeo Association Trustees. Owner(s), exhibitor(s), and/or horse(s) found in violation of the rules by the trustees will lose all points earned

during the days of the show(s) involved. Consistent offenders may lose all points for the current show season and may be suspended from the Tri-State Rodeo Association.

10. Any complaint must be officially registered in writing with the Tri-State Rodeo Association, Inc., Trustees along with twenty-five (\$25.00) dollars. This money will be returned to the person or persons complaining only if the trustees rule in their favor; otherwise, the money will go into the Tri-State Rodeo Association, Inc. treasury. No complaints about a judge's decision will be considered. Protests must be filed the day of the show. All protests will be made in cash only.

11. A judge may officiate at no more than one (1) Tri-State Rodeo Association, Inc., show per year. Any person who has shown a horse at a Tri-State Rodeo Association, Inc., approved show within the current year will not be permitted to judge a Tri-State Rodeo Association, Inc., approved show within the current year. Any horse or pony that has been trained, boarded, or shown within ninety (90) days of the show by the judge officiating at a Tri-State Rodeo Association, Inc., approved show will be ineligible for approved class points. Contest classes are excluded.

12. The judge shall have the authority to place a horse or contestant in whatever position in a class he thinks the merit of the horse or contestant justifies. This decision will be final in all classes affecting the merits of the horse. Once a class has been judged it will not be re-judged. In case of disqualification, all lower placing will move up.

13. The judge, Tri-State Rodeo Association, Inc., stewards and trustees may order any person or horse from the competition for bad conduct from one or both.

14. In the event of a weather delay, the entire show bill must be offered or no points will be counted for the day. No showing when lightning is present. Show will resume under the direction of the Tri-State stewards and judge. Any class interrupted by weather shall be re-judged in its entirety. If contest and performance classes are held on separate days and classes held on one of the days are canceled due to inclement weather, the classes held on the remaining day will retain all points earned on that day.

15. The Tri-State Rodeo Association, Inc. prohibits the use of any stimulant or depressant on any horse competing at an approved show. All horses will be subject to drug testing at any approved Tri-State Rodeo Association, Inc. show. Tri-State Rodeo Association, Inc. will be responsible for the charges. All approved Tri-State Rodeo Association, Inc. show bills will be required to contain the statement that "ALL HORSES WILL BE SUBJECT TO RANDOM DRUG TESTING". If the contestant fails to submit the test or if the test proves to be positive of depressants or stimulants, the contestant will forfeit all accumulated points and will be disqualified for the remainder of the said show season.

16. Any individual wanting a drug test performed on another contestant's horse will present a formally written complaint to the Tri-State Rodeo Association steward along with twenty-five (\$25.00) dollars and the veterinary expenses. If the test is positive, the

association will refund the twenty-five (\$25.00) dollars to the complaining individual. Veterinary expenses will not be refunded. Any contestant must submit his or her horse to a drug test by a licensed veterinarian upon request of the show committee, Tri-State show steward, or official.

17. Tri-State Rodeo Association, Inc. shall put on two approved shows per calendar year. The shows will be called the "Tri-State Rodeo Association, Inc., "Annual Show" and the Tri-State Rodeo Association, Inc., "Fall Round-Up Show". These shows must include all of the Tri-State Rodeo Association, Inc., approved events.

18. There shall be five (5) trophies or awards given to the horse or pony accumulating the most points in a fiscal year for each of the approved events under the hereafter written rules.

19. Tri-State Rodeo Association, Inc. shall provide:

- A. Annual high point awards for each approved class.
- B. Annual all-around high point horse awards.

1. Five (5) awards will be given to the horse and rider team accumulating the most points in the judged performance classes. Each horse and rider must earn points in two (2) or more classes to be judged all-around High Point Performance Horse. Halter Points will count towards High Point Performance Horse Award.

2. Five (5) awards will be given to the horse and rider team accumulating the most points in youth judged performance classes. Each horse and rider must earn points in (2) or more classes to be judged all-around Youth High Point Performance Horse.

3. Five (5) awards will be given to the horse and rider team accumulating the most points in speed events. Each horse and rider must earn points in (2) or more classes to be judged all-around High Point Contest Horse.

4. Five (5) awards will be given to the horse and rider team accumulating the most points in youth timed speed events. Each horse and rider must earn points in (2) or more classes to be judged all-around Youth High Point Contest Horse.

5. Five (5) awards will be given to the horse and rider team accumulating the most points in adult judged performance classes. Each horse and rider must earn points in two (2) or more classes to be judged all-around Adult High Point Performance Horse. Youth and adult high point year end awards will be given one (1) horse and one (1) rider basis.

6. Any ties for Year End High Point Awards will be broken by taking the most number of first places, then second place and so on...

20. Exhibitors must earn a minimum of five (5) points per class and show a minimum of two (2) shows (same class) to be eligible for year end class awards.

21. Trophies and awards shall be furnished by the Tri-State Rodeo Association, Inc., but these may be sponsored by private individuals or clubs of the Tri-State Rodeo Association.

22. The awards and trophies will be presented to the winners at a meeting or banquet to be held succeeding the previous show season. If saddles are awarded, they will be awarded to the persons accumulating the most points in the following categories:

### **Youth Performance**

- Youth Showmanship
- Youth Horsemanship
- Youth Western Pleasure
- Youth English Equitation

### **Adult Performance**

- Adult Showmanship
- Adult Horsemanship
- Adult Western Pleasure
- Adult English Equitation

### **Open Performance**

- Halter
- Western Pleasure
- English Pleasure
- Trail or Trail In Hand
- Egg and Spoon

### **Open Contesting**

- Barrels
- Poles
- Flag Race
- Ball Race
- Down & Back

### **Youth Contesting**

- Youth Barrels
- Youth Poles
- Youth Flag Race
- Youth Ball Race
- Youth Down & Back

If saddles are awarded, there will be at least one for the high point performance category and one for the high point contesting category.

23. To earn points toward the year-end awards which are offered, the exhibitor and the owner of the horse or pony being shown must be members of the Tri-State Rodeo Association, Inc. Membership applications with the proper fees and proof of ownership must be either in the hands of the membership secretary on the day of the show, or be postmarked the business day following the show. Exhibitor will be responsible for sending all necessary information to the membership secretary for the current show season. All papers on file with the membership secretary for the previous show season will be returned at the annual awards banquet. All papers on file will be destroyed 60 days following the annual banquet. Tri-State Rodeo Association, Inc., will not be responsible for files that are not claimed.

24. Proof of ownership of horses and ponies in the Tri-State Rodeo Association, Inc., shall be as follows:

Registered Horses:

**ORIGINAL BREED ASSOCIATION**

Registration papers. Double registered animal must designate choice of registration at beginning of show season and must be retained for entire show season. Animal is not eligible for any other registered class.

Grade Horses and Ponies:

Signed statement of ownership and two (2) pictures of horse or pony (one (1) of each side) to be turned in to the membership secretary for her records.

Weanlings:

To be eligible for year end awards, owner must fill out a Tri-State weanling form. Class entries for unnamed weanlings shall be listed with sire and dam name.

Members exhibiting leased horses must submit a Tri-State approved lease form to the membership secretary with their membership application. If a new horse is purchased during show season, the owner will be given a sixty (60) day grace period from date of purchase to provide a copy of the transfer or ownership qualification papers (as listed below) to the membership secretary postmarked no later than the first business day after the horse is shown to earn points for that show.

Ownership qualifications for the Tri-State Rodeo Association, Inc., are:

1. Original breed registration papers.
2. Tri-State Rodeo Association, Inc. approved lease.
3. Signed statement of ownership accompanied by pictures.

25. Exhibitors to be solely responsible for accuracy and completeness of class entry. Horse, rider and owner must be listed on entry form. Exhibitor not entered in a class is

disqualified. Entry fees not paid day of show or checks not clearing bank will cause entrant to lose all points for the day.

26. Show committee shall be responsible for working and watering the arenas as necessary, and for providing adequate arena help.

27. Each club will be responsible for sending:

- (1) The number of entries shown in each class.
- (2) The names of the horse, the owner, and the exhibitor for each entry must be listed on class sheet.
- (3) The first six (6) places in each class.
- (4) One fully completed set of class sheets provided by the Tri-State Rodeo Association, Inc. to the member club with judges cards stapled to each to the appropriate point secretary postmarked no later than one (1) business day after the show date. The check for the awards fund for all Tri-State Rodeo Association Inc. approved classes must accompany the sheets sent to the point secretary. Failure to comply will cause the member club to lose their escrow for the show.

28. Points will be awarded to the first five (5) horses placing in each approved class according to the point system providing Rule #24 has been followed. Points will be awarded to only qualified runs in the timed events. Points to be awarded are as follows: For a class of five (5) or more horses, the first place horse receives five (5) points, second place horse receives four (4) points, third place horse receives three (3) points, fourth place horse receives two (2) points, and the fifth place horse receives one (1) point. The same applies if there are four or fewer entries in a class. The first place horse gets no more points than there were horses in the class. The remaining horses receive one (1) point plus one (1) point for each horse placing below them.

### **POINT SYSTEM**

<b>Number in class</b>	<b>1<sup>st</sup> Place</b>	<b>2<sup>nd</sup> Place</b>	<b>3<sup>rd</sup> Place</b>	<b>4<sup>th</sup> Place</b>	<b>5<sup>th</sup> Place</b>
<b>1</b>	1 pt				
<b>2</b>	2 pts	1 pt			
<b>3</b>	3 pts	2 pts	1 pt		
<b>4</b>	4 pts	3 pts	2 pts	1 pt	
<b>5 or more</b>	5 pts	4 pts	3 pts	2 pts	1 pt

29. Points will be posted weekly during the show season. The President shall appoint an audit committee consisting of officers, delegates, and trustees. A mid season audit shall be conducted in the third week of July and/or at the President's direction. Final standings will not be official until the completion of the year end point standings and membership packet audit.

30. Ponies will be measured by the Tri-State Rodeo Association, Inc. Stewards on the first showing of said pony if any pony is in question of a height of 58" or under. Any

animal over 59" is considered a horse by this association. Double registered animals must follow rule #24.

31. All exhibitors must wear English or Western Boots, English or Western attire. In timed speed events, western shirt must have a collar & a four (4) inch sleeve.

32. No horse may be shown by more than one (1) contestant in any one (1) class on the same day.

33. Queen/King candidates must have been a member of Tri-State Rodeo Association, Inc. prior to the current year and be 15 years or older to be eligible to compete.

34. Tri-State Rodeo Association, Inc. rules will apply for one (1) year.

35. Any persons are eligible to participate in this program as long as all Tri-State Rodeo Association, Inc., rules are adhered to with no exceptions.

36. All Tri-State Rodeo Association, Inc., approved classes must be conducted to the rules listed. NO other rules will be considered.

## **II. HALTER CLASSES**

Each club that participates in the Tri-State Rodeo Association, Inc. Halter program must include approved halter classes one (1) through five (5). The clubs may choose any other halter classes. Only objects and personnel required to run that particular class will be allowed in the arena. Horses and ponies are eligible to show in only one (1) approved halter class, with the exception of weanlings and yearlings. Double registered horses must designate choice of registration at beginning of show season, and must retain for entire show season. Horse is not eligible for any other registered class.

(1.) WESTERN TYPE PONY (58" and under) Ponies to be shown in natural stance. Geldings, mares and stallions are eligible.

(2.) OPEN HORSE HALTER  
(No A.Q.H.A., A.P.H.A., or Pt.HA)

(3.) QUARTER HORSE MARES  
All entries must have current A.Q.H.A. registration papers.

(4.) QUARTER HORSE GELDINGS & STALLIONS  
All entries must have current A.Q.H.A. registration papers.

(5.) PAINT & PINTO  
All entries must have A.P.H.A. or Pt.H.A. registration papers. Open to mares, geldings, and stallions.



(6.) YEARLING FOALS

Open to all sexes of all breeds foaled from January 1 through December 31 of the preceding year. Not eligible for all-around high point award. May show in respective breed class.

(7.) WEANLING FOALS

Open to all sexes of all breeds foaled from January 1 through December 31 of the current year. Not eligible for all-around high point award. May show in respective breed class.

### III. JUDGED PERFORMANCE CLASSES

Each club that participates in a Tri-State Rodeo Association, Inc., approved show must have on their program performance classes one (1) through five (5). All approved events scheduled for any given show program and designated as such are eligible for point accumulation. Only objects and personnel required to run that particular class will be allowed in the arena. Classes one (1) through five (5) will be mandatory. In all pleasure classes, horses and ponies must work both ways of the arena at all three (3) gaits to determine their working ability with different leads. The judge may ask for additional work or maneuvers after rail work. No wire curbs or tie downs are permitted.

(1.) QUARTER HORSE PLEASURE (Seat optional)

All horses must be registered with A.Q.H.A.

(2.) OPEN HORSE PLEASURE (No. A.Q.H.A., A.P.H.A., or Pt.H.A.) (Seat optional)

Open to mares, geldings, and stallions. Double registered animals must follow rule #25.

(3.) PONY PLEASURE (Seat optional)

Ponies to be 58" and under.

(4.) PAINT & PINTO PLEASURE (Seat Optional)

All horses must be registered with the A.P.H.A. or Pt.H.A.

(5.) ENGLISH PLEASURE (Open)

(Seat optional)

(6.) JUNIOR PLEASURE, (Open)

(Seat optional) Open to all breeds, 5 years and under. Will not count towards year-end awards.

(7.) EGG & SPOON (Open)

An egg shall be placed in the base of a spoon with out any type of adhesive. The spoon shall be held by the end of the handle between the thumb and the first finger.

Instructions will be given by the judge and if not so followed, the contestant may be disqualified. A metal or plastic spoon may be used.

#### (8.) TRAIL CLASS (Open)

Trail class pattern to be posted one (1) hour before class. Six (6) obstacles or more will be used from the approved list. Three (3) of which are mandatory, and three (3) or more will be optional. The gait between the obstacles shall be set at the discretion of the judge. Ground tie obstacle is not permitted in Trail Class.

Scores will be announced after each individual ride. Trail Class must be offered with Trail In Hand.

#### MANDATORY OBSTACLES ARE AS FOLLOWS:

1. Open, passing through and closing a rope gate.
2. Passover at least four (4) logs.
3. Passover a wooden bridge.

#### SUGGESTED OPTIONAL OBSTACLES ARE:

1. Back horse through "L" shaped course.
2. Remove and replace material from mail box.
3. Side pass.
4. Back through and around three (3) markers set in either a triangle or on a line.
5. The obstacles consisting of four (4) logs or rails, each five (5) to six (6) feet long, laid in a square. Each contestant will enter the square by stepping over the log or rail at designated side. When all four (4) feet are inside the square, rider will execute a 360 degree turn (right to left), pause and depart by stepping over the log or rail immediately opposite side of entry.
6. Put on and remove a slicker.

#### (9.) TRAIL IN HAND (Open)

Exhibitor must designate Trail or Trail In Hand at the beginning of the show season, and must show in the designated class for the entire show season. Trail In Hand (Open) must be offered with Trail Class (Open).

Horse or pony to be shown in a halter. Leads must be at least twelve (12) feet in length and no longer than twenty-five (25) feet. A chain lead is allowed over or under the nose. A whip is optional.

Obstacles shall be the same as those used in the Trail Class. Gaits between obstacles are limited to the walk, jog and/or trot.

Exhibitors should not touch the horse while negotiating obstacles and may not use food rewards to bait the horse. Exhibitors may pet the horse briefly after completion of an obstacle.

Exhibitors may change hands on the lead as necessary to perform the obstacle. The exhibitor may wave his/her free arm/hand and/or the end of the lead to encourage the horse without touching it.

#### (10). REINING CLASS. (Open)

TRI -STATE RODEO ASSOCIATION, INC. patterns to apply. Judge will stand according to the pattern with the entrance gate determining the starting line of the pattern. The pattern selected by the judge shall be posted at least one hour before the class. Each contestant will perform the required pattern individually and separately. Horse shall rein and handle easily, fluently, and effortlessly with reasonable speed throughout the pattern.

Curb chains are permissible, but must meet the approval of the judge, must be at least one-half inch in width and lie flat against the jaw of the horse. No wire curbs, regardless of how padded or no chain strap narrower than one-half inch, no martingales, no nose bands or tie downs will be permitted.

The use of more than one finger between the reins, using two hands or changing hands on the reins shall result in disqualification with the exception of snaffle bit or hackamore horses five (5) years of age or younger.

Any horse not following exact pattern will be disqualified.

Placing and points will be given only to qualified runs.

Scores to be announced after each ride.

The arena or plot should be approximately 50 x 150 feet in size. The judge shall indicate with markers on arena fence or wall the length of the pattern. Markers along fence or wall are mandatory. Markers within the area of the pattern will not be permitted.

### Reining Pattern One (1)

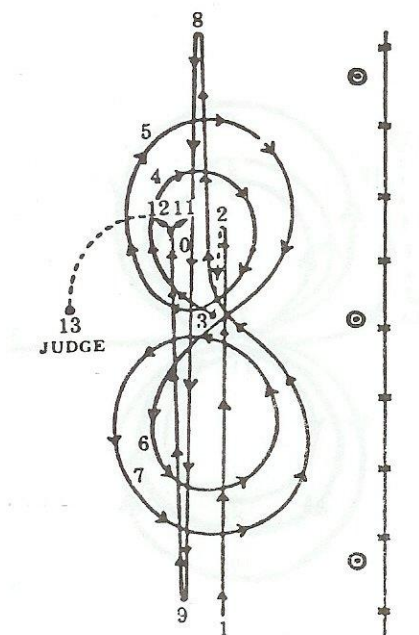

Ride pattern as follows:

- 1 to 2 - Ride with speed past center marker.
- 2 - stop and back up to center of pattern.
- 3 - Settle horse for approximately 10' seconds. Start lope. Circles should be made inside of end markers.
- 4 to 5 - Ride two (2) circles to the right, first circle small, should be slow, and second circle larger and faster.
- 6 to 7 - Ride two (2) circles to the left, first circle small, should be slow, and second circle larger and faster. 8 - Left rollback over hocks (should be made past far end marker).
- 9 - Right roll back over hocks (should be made past near end marker).
- 10 - Stop (should be made past center marker). Let horse settle, then in approximate area of stop, do the pivots.
- 11 - Pivot right or left no more than 90 degrees.
- 12 - Pivot opposite direction, no more than 180 degrees.
- 13 - Walk to judge and stop for inspection until dismissed.

### Reining Pattern Two (2)

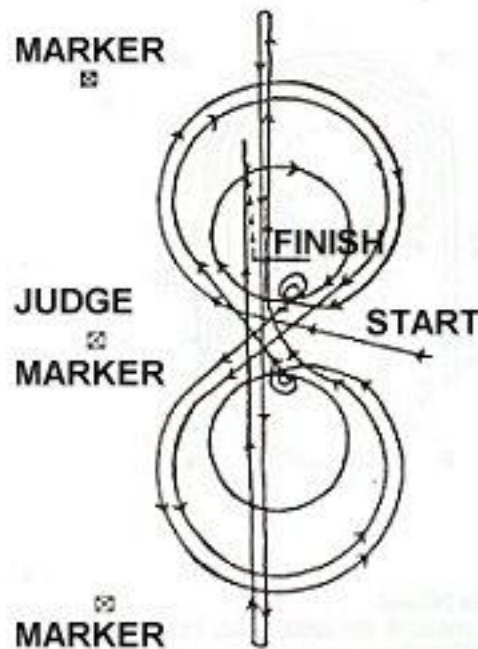

Ride pattern as follows:

- 1 - Starting in center of arena, make a large fast circle.
- 2 - Draw the circle down to a small slow circle until you reach the center of the arena - stop without hesitation do a double spin to the inside - at end of spins horse should be facing the left wall - slight hesitation.

- 3 - Begin on the left lead and make a large fast circle.
- 4 - Then a small slow circle again drawing it down to the center of the arena - stop - and without hesitation do double spin to the inside of the circle - hesitate - horse to be facing left wall.
- 5 - Begin on the right lead and make a fast figure eight over the large circles - close the eight - and change leads.
- 6 - Run to the far end of the arena and do a left roll back.
- 7 - Run to the opposite end of the arena and do a right roll back.
- 8 - Run back passed the center of the arena and do sliding stop. Hesitate.
- 9 - Back over your slide tracks.
- 10 - Report to the judge and then leave the arena.

### Reining Pattern Three (3)

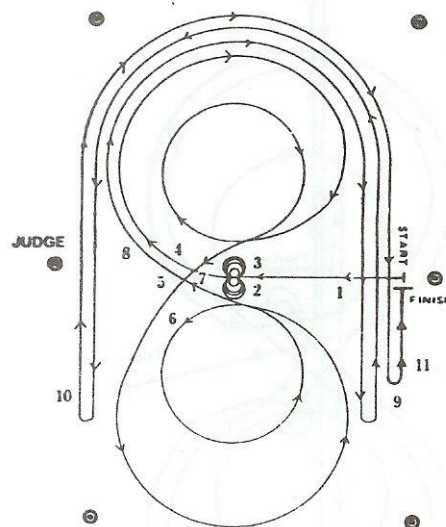

Ride Pattern as follows:

- 1 - Walk to center of the arena, stop, horse should be facing left wall or fence.
- 2 - Complete four spins to the left.
- 3 - Complete four spins to the right. Hesitate.
- 4 - Begin on right lead and complete two circles to the right. The first circle large and fast - the second circle small and slow.
- 5 - Change leads at the center of the arena.
- 6 - Complete two circles to the left. The first circle large and fast - the second circle small and slow.
- 7 - Change leads at the center of the arena.
- 8 - Begin a large fast cycle to the right. Do not close this circle but run straight down the side past the center marker and do a left roll back at least twenty feet from the wall or fence, no hesitation.

9 - Continue back around top half of previous circle, do not close this circle but run straight down opposite side of the arena past center marker and do a right roll back at least twenty feet from wall or fence - no hesitation. \*\*\*

10 - Continue back around previous circle, do not close this circle but run straight down the side past the center marker and do a sliding stop at approximately twenty feet from the wall or fence.

11 - Back straight to the center of the arena.

\*\*\* Horse may come out of roll back on either lead however it should be on correct lead going around the end of the arena.

#### **IV. TIMED SPEED EVENTS**

Each club that participates in TRI-STATE RODEO ASSOCIATION, INC., approved show must have on their program at least eight (8) of the fourteen (14) approved timed speed events. All approved events scheduled for any given show program and designated as such are eligible for point accumulation. Only objects and personnel required to run that particular class will be allowed in the arena. Only participants will be permitted in the arena. Lead-ins or assistants are permitted to get the horse and rider through gate only. Ten (10) foot entrance maximum.

1. All courses should be set so the horse has ample room to run and stop. All obstacles' placements must be visibly marked with a substance other than the arena's dirt.
2. There will be a forty-five (45) second time limit from entering gate to crossing the start line or it will result in disqualification.
3. Any obstacle knocked over or moved more than the width of the base in any class by direct contact by horse or rider will result in disqualification.
4. At the discretion of the Judge, Tri-State Steward or Trustees, any contestant may be disqualified from a class and or the show for any abusive hitting of their horse in the front of the cinch either in the arena or outside the arena, (See General Rule 13). Points will be given only for qualified runs in timed speed events. There will be no re runs for broken equipment.
5. All member clubs having a TRI-STATE RODEO ASSOCIATION, INC., approved show must use equipment provided by the Association. The approved equipment will consist of the following:

1. Pole Bending: Poles
2. Indiana Style Flag Race: Flags and Buckets
3. Barrel Race: Barrel pads
4. Ball Race: Balls

A list of this equipment shall be included in show packets to member club.

6. It will be mandatory that the TRI-STATE RODEO ASSOCIATION, INC., steward will position the judge on all timed speed events.

7. Electric timer shall be mandatory for all timed speed events. If the electric timer fails and must be changed during a class, the entire class must be re-run with the new timer. All times must be announced.

8. If a contestant makes a qualified run the first time and the timer fails to work for any reason, the contestant will be permitted to re-run no more than twice to qualify.

9. The judge may prohibit the use of bits or equipment he considers too severe or inhumane.

(1.) CLOVERLEAF (Open)

Barrel #1 and #2 must be set equal distance from the starting line. Barrel #3 must be set equal distance from barrel #1 and #2. The contestant will run to the barrel on the right or barrel #1, pass to the left of it and complete an approximate 360 degree turn around it, then go the barrel on the left, or barrel #2, pass to the right of it and complete a slightly more than 360 degree turn around it then to barrel #3, pass to the right of it and do another approximate 360 degree turn around it to the left and then sprint to the finish line, passing between barrel #1 and barrel #2. Course may be run either to the left or right.

(2.) 3-D BARRELS (Open)

Same pattern as Open Cloverleaf. Does not count toward all-around high point contest award. 3-D placing bracket to be posted in entry booth.

(3.) INDIANA STYLE FLAG RACE (Open)

Course to run around three (3), 55 gallon barrels set in a cloverleaf pattern with a five (5) gallon container placed on the first and third barrels. The flag must be twenty (20) inches long. The flag staff must be rounded wood and not exceed one (1") in diameter. Each five (5) gallon container must be equally filled with at least six (6) inches of dirt or sand. The flag must be taken from the first container and placed in the second container to qualify. If run is started on the inside of the first barrel, it must be completed on the inside of the third barrel. All runs must go outside the second barrel.

(4.) POLE BENDING (Open)

The pole bending pattern is to be run around six (6) poles. The poles are to be twenty-one (21) feet from the starting line. Poles shall be set on top of the ground six (6) feet in height and with no base more than fourteen (14) inches in diameter. A horse may start either to the right or to the left of the first pole and then run the remainder of the pattern.

(5).3-D POLE BENDING (Open)

Same pattern as Open Pole Bending. Does not count toward all-around high point contest award. 3-D placing bracket to be posted in entry booth.

(6.) DOWN AND BACK (Open)

Course to be run around one (1) pylon or plastic cone at least fifteen (15) inches but not more than twenty-four (24) inches high set at the far end of the arena.

(7.) BALL RACE (Open)

Course to be run around one (1) open top fifty-five (55) gallon barrel. Barrel must be placed in center of arena at one end. A ball will be carried from the starting line and deposited in the barrel at the other end of the arena. Course to be completed when horse crosses the finish line.

### **YOUTH TIMED SPEED EVENTS**

(1.) CLOVERLEAF (8 years and under)

Same pattern and rules as Cloverleaf Open. Must be offered with Cloverleaf 9 through 13 years and 14 through 18 years. Eligible for Western Showmanship (8 years and under) and Pole Bending (8 years and under).

(1.) CLOVERLEAF (9 years through 13 years) Same pattern and rules as Cloverleaf Open. Must be offered with Cloverleaf 8 years and under and 14 through 18 years.

(3.) CLOVERLEAF (14 years through 18 years) Same pattern and rules as Cloverleaf Open. Must be offered with Cloverleaf 8 years and under and 9 through 13 years.

(4.) POLE BENDING (8 years and under) Same pattern and rules as Pole Bending Open. Must be offered with Pole Bending 9 through 13 years and 14 through 18 years. Eligible for Western Showmanship (8 years and under) and Cloverleaf (8 years and under).

(5.) POLE BENDING (9 through 13 years) Same pattern and rules as Pole Bending Open. Must be offered with Pole Bending 8 years and under and 14 through 18 years.

(6.) POLE BENDING (14 years through 18 years) Same pattern and rules as Pole Bending Open. Must be offered with Pole Bending 8 years and under and 9 through 13 years.

(7.) DOWN AND BACK (18 years and under) Same pattern and rules as Down and Back Open.

(8.) BALL RACE (18 years and under) Same pattern and rules as Ball Race Open.

### **V. YOUTH EVENTS**



1. In all Tri-State Rodeo Association, Inc., approved classes youth shall be defined as any rider eighteen (18) years of age and under as of January first (1st) of the current year.
2. All youth must present a copy of their birth certificate to membership secretary at the time of signing up for membership in the Tri-State Rodeo Association, Inc.
3. In all youth classes, immediate family must own or lease horse or pony; father, mother, sister, brother, grandparents or legal guardian. The proof must be turned in to the membership secretary before any points will count.
4. Any infraction of the youth ownership rule as determined by the Trustees will cause the exhibitor to lose all points earned for the current show season by vote of the Trustees.
5. In Youth Classes, the same horse may be shown by more than one immediate family member in different subdivisions on the same day. (Example: A horse ridden in Horsemanship (13 and under) by one youth could then be ridden by an immediate family member in Horsemanship (14 years through 18 years).
6. No youth Tri-State Rodeo Association, Inc. approved class can be Calcutta.

### **SHOWMANSHIP CLASSES**

Exhibitor's age to be determined as of January first (1st.) of the current year. Horse or pony may be shown. Exhibitor may show a mare or gelding. **NO STALLIONS ALLOWED.** Exhibitor judged on the fitting and grooming of the horse and on the ability of the showman to present the horse properly and to its best advantage. Type, conformation and quality of the horse have no bearing on the judging of these classes. Manners and response to the showman however, do indicate the degree of training received by the animal and should be credited to the showman.

Classes one (1), two (2), and three (3) of the approved showmanship classes listed below must be offered.

- (1.) WESTERN SHOWMANSHIP (8 yrs. and under)
- (2.) WESTERN SHOWMANSHIP (9 yrs. through 13 yrs.)
- (3.) WESTERN SHOWMANSHIP (14 yrs. through 18 yrs.)
- (4.) ENGLISH SHOWMANSHIP (18 yrs. and under)

## **PERFORMANCE CLASSES**

Each club that participates in a Tri-State Rodeo Association Inc. approved show that offers horsemanship or equitation classes must offer all age breaks.

Exhibitor's age to be determined as of January first (1st) of the current year. Horse or pony may be shown. Exhibitor may show a mare or gelding. **NO STALLIONS ALLOWED.** Horse or pony must work both ways of the arena at all three (3) gaits to determine their working ability with different leads. No wire curbs or tie downs are permitted. The judge may ask for additional work or maneuvers after rail work. The use of western chaps in all horsemanship classes shall be optional.

- (1.) WESTERN HORSEMANSHIP (13 yrs. and under)
- (2.) WESTERN HORSEMANSHIP (14 yrs. through 18 yrs.)
- (3.) ENGLISH EQUITATION (13 yrs. and under)
- (4.) ENGLISH EQUITATION (14 yrs. through 18 yrs.)
- (5.) WESTERN PLEASURE (18 yrs. and under)
- (6.) WALK-TROT PLEASURE (18 yrs. and under) Seat optional. Horses to work both ways of the ring at a walk and trot or jog. One or the other of the horse or rider can not compete in a canter class. Not eligible for year-end high point award.
- (7.) ENGLISH PLEASURE (HUNTER UNDER SADDLE) (18 yrs. and under)  
(Seat optional)

## **VI. PEE WEE HORSEMANSHIP**

Leases or family ownership rule do not apply in this division.

(1.) LEAD-IN-CLASS (Rider 6 years and under) Any rider that enters any other Tri-State Rodeo Association, Inc. approved riding class during the current show season will no longer be eligible for this class. They are eligible for Halter classes and Western Showmanship (8 and under). **NO STALLIONS ALLOWED. \*\***

(2.) WALK-TROT (Rider 8 years and under)  
Horse or pony must work both ways of the whole arena at both the walk and trot or jog gaits. Any rider that enters any other Tri-State Rodeo Association, Inc. approved riding class during the current show season will no longer be eligible for this class. They are eligible for Halter classes and Western Showmanship (8 and under).  
**NO STALLIONS ALLOWED. \*\***

\*\* Not eligible for year-end high point award.

## **VII. ADULT CLASSES**

Stallions may be shown in adult classes.

(1.) ENGLISH or WESTERN SHOWMANSHIP (19 yrs. and over)

(2.) WESTERN HORSEMANSHIP (19 yrs. and over)

(3.) ENGLISH EQUITATION (19 yrs. and over)

(4.) WALK-TROT PLEASURE (19 yrs. and over) Seat optional. Horses to work both ways of the ring at a walk and trot or jog. One or the other of the horse or rider can not compete in a canter class. Not eligible for year-end high point award.

(5.) WESTERN PLEASURE (19 yrs. and over)

(6.) ENGLISH PLEASURE (HUNTER UNDER SADDLE) (19 yrs. and over)  
(Seat optional)

## **VIII. QUEEN/KING PAGEANT RULES**

1. Each candidate must be 15 years or older and never reigned as a Tri-State Queen. Candidates may be married or single and still be eligible.

2. Each candidate must have been a prior member of the Tri-State Rodeo Association and also a current member through either a family membership or an individual membership. An application for membership may be obtained from any Tri-state official.

3. A candidate may represent a club, stable, or may run as an independent candidate. A club may sponsor more than one candidate.

4. Each candidate must fill out an application and return it with a \$20.00 entry fee to the Director(s) no later than June 5th. Checks only, please, should be made payable to the Director.

5. A 5" x 7" glossy portrait photograph of head and shoulders only is required. These portraits should be in show attire if possible. This should be sent in with the application by June 5<sup>th</sup>. On the back of the portrait clearly print your name, club, stable, or independent candidate.

6. Autobiographies must accompany each candidate's application. This should be contained in a folder or booklet form and typewritten. Autobiographies will be written on

the basis of the questions posed on the application form. All autobiographies are to be anonymous and approximately 500 to 800 words.

7. There are 4 main divisions of judging. These include:

**AUTOBIOGRAPHY:** Judged on neatness, spelling, grammar, writing, mechanics, conciseness, organization, originality, and presentation. '

**SOCIAL FINESSE:** Judged on poise, personality, appearance and speaking ability at a dinner given in honor of the candidates.

**HORSE KNOWLEDGE:** Judged on written test. Time to be announced at a later date.

**HORSEMANSHIP SKILLS:** Judged on 3 out of 5 different classes. The classes to choose from are Showmanship, Western Horsemanship, English Equitation, Barrels, and Poles. Candidates must show in a performance class, a contest class, and one class of your choice. The same horse must be used in all 3 classes.

Please give a list of the 3 classes you have chosen to the Director. In the rare event of a tie for Queen/King, First or Second runner-up, the tie will be by the highest score on the Horse Knowledge division.

8. The Queen/King, First, and Second runner-up will be chosen on the basis of total points accumulated in the four divisions. If there are more than four candidates, a Miss Congeniality will be chosen by a vote among the candidates on the night of the banquet. Otherwise the directors will choose this position.

9. The Coronation Ceremony will take place at the Tri-state Awards Banquet.

10. Anyone found cheating in the contest will automatically be dropped from the competition.

11. Obligations of the Queen/King candidates:

- \* Candidates must show in their three specified classes at BOTH the Annual and Fall Roundup shows and must use the same horse at both shows.
- \* Participate in at least one Grand Entry per TSRA show weekend.
- \* Show at a majority of shows (one more than 1/2).
- \* Attend a majority of TSRA meetings (one more than 1/2).
- \* Assist at shows as needed.
- \* Assist at Wood County Flea Markets

12. Obligations of the Queen/King for year crowned:

- \* Show at a majority of shows (one more than 1/2).
- \* Organize grand entries at all shows.
- \* Work as public relations at all times.
- \* Help out at shows as needed.

- \* Must attend Tri-state meetings.
- \* Will be official reporter and be responsible for submitting articles to the Horsemen's Corral.
- \* Assist with awards at the banquet.
- \* Assist at Wood County Flea Markets.
- \* Automatically be put on the Queen/King Committee for the following year.

13. Candidates will receive letters from time to time and should keep all correspondence from the Director(s). Questions from candidates should be directed to the Queen/King Director(s).

## **IX. CONSTITUTION OF THE TRI-STATE RODEO ASSOCIATION, INC.**

### **ARTICLE I Name**

Name of this association shall be Tri-State Rodeo Association, Inc.

### **ARTICLE II Purpose**

The Purpose of this association shall be:

Section 1: To improve the quality and promote the use of all light horse breeds, and to promote harmony and cooperation within our organization and all it's clubs.

Section 2: To keep a list of all Tri-State Rodeo Association approved events and avoid conflicting dates.

Section 3: To study the laws, rules and regulations pertaining to the horse and its uses and to use our influence to promote laws and regulations beneficial to our purposes.

Section 4: To formulate rules of Tri-State Rodeo Association approved events which may be used by member clubs.

Section 5. To aid and encourage all youth to manage horses safely.

### **ARTICLE III Membership**

Section 1. Membership shall consist of three (3) categories:

a. Clubs and organizations which are formed to promote interest in horses and horsemanship.

b. Family memberships will include the parents and their minor children (18) years and under as of January 1st who qualify for the Youth Activity Program and/or husband and wife.

c. Individual membership for those persons who do not qualify under the Family Membership Plan or those who do not qualify for the Youth Activity Program.

Section 2. Any club or organization wanting to become a member of the Tri-State Rodeo Association, Inc. may express interest with any Tri-State officer or at any Tri-State meeting. All clubs or organizations expressing interest should be of good repute with interest in promoting horses. The fee to join is (\$10.00) dollars per year as stated under general rules, item five (5).

Section 3. Any club, organization, family, or individual having joined the association shall thereby become subject to all the Rules and By-Laws of the association and shall be subject to suspension or expulsion from the organization for bad conduct or infraction of the rules by recommendation for the Trustees after a full and fair hearing of the facts, and by a vote of two-thirds (2/3) of the delegates, officers, and trustees present at a regular meeting.

Section 4. Any club or organization is automatically dropped to the bottom of the seniority list by not being represented at two (2) consecutive meetings unless they are excused by an officer.

Section 5. Each club and organization shall be represented by two (2) delegates whose names and addresses shall be furnished to the Tri-State Rodeo Association Secretary for a mailing list.

Section 6. The most recent list on file shall be used to determine the club's seniority.

#### **ARTICLE IV Officers**

Section 1. The officers shall consist of a President, Vice-President, a Secretary, and a Treasurer which will be elected by a majority vote of the voting members. They will serve for one (1) years, or until their successors are elected.

Section 2. A board of ten (10) Trustees shall be elected in the following manner:

a. Five (5) Trustees shall be elected from the clubs' delegates to serve for a period of two (2) years as follows:

1.) November 1969, three (3) elected for two (2) years, and two (2) elected for one (1) year.

2.) Thereafter, all elected terms shall be two (2) years.

b. And five (5) Trustees shall be elected from the membership at large to serve for a period of two (2) years as follows:

1.) In 1975, during the month of February, the five (5) trustees elected by the club delegates will appoint three (3) trustees to serve for a two (2) year period and two (2) trustees to serve for a period of one (1) year.

2.) Thereafter, all elected terms shall be for a period of two (2) years.

3.) A trustee missing more than two (2) consecutive meetings unexcused is subject to dismissal by vote of trustees.

c. Any individual elected from the body of delegates to serve as a trustee shall retain his vote as a delegate, thereby he shall have two (2) votes on any issue requiring a vote by both delegates and trustees.

Section 3. The annual election of officers will be held at the annual awards banquet with installation at the next regular meeting. Each club will have the vote of the two (2) delegates, each family will have two (2) votes, and each individual member will have one (1) vote.

Section 4. Nomination for officers and trustees will be made either by the Nominating Committee Chairman or from the floor at a regular meeting. Nominations shall be made to the nominating Committee before the last regular meeting held prior to the annual awards banquet.

Section 5. Persons running for office must have been a member or delegate of Tri-State Rodeo Association, Inc. the prior year.

Section 6. Persons holding office must be a member or delegate of Tri-State Rodeo Association, Inc. during term of office.

## **ARTICLE V MEETINGS**

Section 1. Meetings shall always be held on the second Wednesday of each month.

Section 2. Regular meetings are open to the world. However, only recognized delegates, officers, and trustees will be permitted to vote.

Section 3. All meetings shall be conducted according to ROBERTS RULES OF ORDER.

## **ARTICLE VI QUORUM**

A quorum shall consist of two-thirds (2/3) of the officers, trustees and voting delegates.

## **ARTICLE VII DUES**

The annual dues are subject to change by a quorum vote.

## **ARTICLE VIII AMENDMENTS**

Section 1. This constitution may be amended by a majority vote of the officers, trustees, and voting delegates present provided that the amendment has been read previously at two (2) regular meetings.

Section 2. The By-Laws may be amended by a Majority vote of the officers, trustees, and voting delegates present at a regular meeting.

## **ARTICLE X BY-LAWS**

1. The meeting shall commence at seven (7:00) P.M.
2. The association shall sponsor a Queen/King Pageant.
3. The President shall appoint Point Secretaries as needed.
4. The Vice-President shall be Chairman of the Annual and Fall Round-Up Horse Shows and shall pick the show dates at the regular December meeting of each year according to rule ten (10) of the By-Laws.
5. The reigning Queen/King shall be the News Reporter or the President shall appoint one (1) if needed.
6. Should a Trustee not be able to serve his full term, his successor will be appointed, for the balance of his term, by the trustees.
7. Current show rules are hereby considered to be part of the By-Laws.
8. An Auditing Committee of three (3) delegates or a registered accountant other than officers or trustees shall audit the association books and shall issue a statement of facts after the election of and prior to the installation of the new officers.
9. Each member club shall provide one (1) official performance show steward and one (1) official contest show steward to serve at each Tri-State Rodeo Association, Inc. approved show sponsored by their club. The steward's names must be posted at the entry booth or be listed on the show bill.



10. Show dates will be chosen in December of each year at the regular meeting. The club with the most seniority will have the first chance at retaining it's previous show date and may elect to take a new date after all the clubs have stated their choices of the previous year's show dates. Seniority will determine the order of choosing show dates. Section 2, Article III explains method of determining seniority.

Updated 2014